

# HIGHBAY

## LX-HB-03-G3(C2)



|                 |            |                   |
|-----------------|------------|-------------------|
| <b>IP</b><br>65 | AC110-277V | <b>CRI</b><br>>80 |
|-----------------|------------|-------------------|



### HIGHBAY HB-03-G3(C2)

Factories, Steel Mills, Steel Smelting Plants, Farms, sport Facilities & Workshops, Storage Facilities & Warehouses, Supermarkets & Department Stores, Showrooms, Design Centers & Galleries.

Microwave Motion Sensor

Operating Temp.: -40°C ~+50°C

Operating Temp.: -40°C ~+80°C

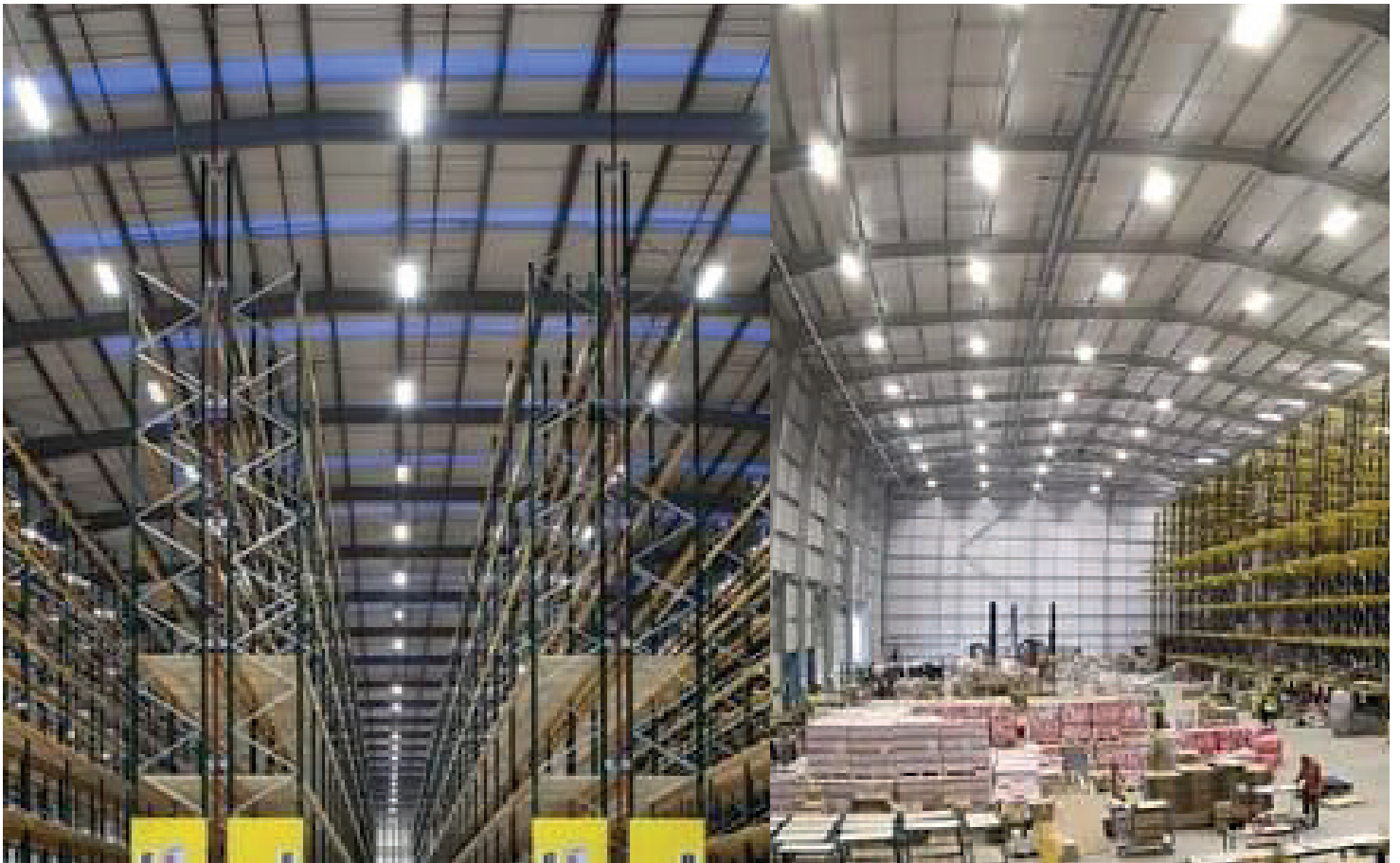

**luxio**  
L I G H T I N G

[www.luxio-lighting.com](http://www.luxio-lighting.com)

## References

| Reference       | Led Power | Luminous flux | CCT/K                    | OPTICS   | IP Rating | Dimensions          | Net Weight       |
|-----------------|-----------|---------------|--------------------------|----------|-----------|---------------------|------------------|
| LX-HB-03-G3(C2) | 50W       | 6500lm        | 3000K/4000K/5000K /5700K | 60°*100° | IP65      | 305.84*135.87*90mm  | 2.00kg (4.4Lbs)  |
|                 | 100W      | 13000lm       |                          |          |           | 580.84*135.87*90mm  | 3.22kg (7.1Lbs)  |
|                 | 150W      | 19500lm       |                          |          |           | 857.84*135.87*90mm  | 4.37kg (9.6Lbs)  |
|                 | 200W      | 26000lm       |                          |          |           | 1134.84*135.87*90mm | 5.51kg (12.1Lbs) |

Order code : Reference - Power - Luminous flux - CCT/K - Optic

Important : All the specification can be customized as per the project request .

## Model Options



## Dimensions(mm)

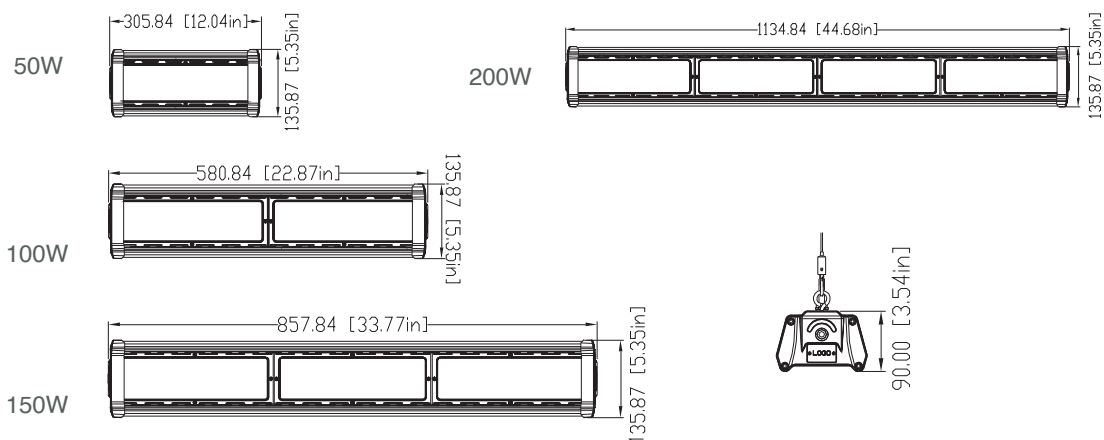

# Installation and use

## P1 Hanging Installation (Standard)

01

| Power | Qty |
|-------|-----|
| 50W   | 2   |
| 100W  | 2   |
| 150W  | 2   |
| 200W  | 2   |

02

| Power | L      | D   |
|-------|--------|-----|
| 50W   | 285mm  | 8mm |
| 100W  | 570mm  | 8mm |
| 150W  | 855mm  | 8mm |
| 200W  | 1140mm | 8mm |

03

04

05

06

07

Brown - L  
Blue - N  
G/Y - GND

08

## P2 Ceiling Installation

01

| Power | Qty |
|-------|-----|
| 50W   | 2   |
| 100W  | 2   |
| 150W  | 2   |
| 200W  | 2   |

02

| Power | L     | D   |
|-------|-------|-----|
| 50W   | 185mm | 8mm |
| 100W  | 360mm | 8mm |
| 150W  | 540mm | 8mm |
| 200W  | 720mm | 8mm |

03

04

05

06

Brown - L  
Blue - N  
G/Y - GND

07

50°

50°

Caution:  
vertical installation  
is absolutely not permitted